

Operation Manual

Versa-Pak V8X

By PSI Waste Equipment Services, Inc.
 Versa-Pak V8X SUPPORT www.versa-pak.net
 Phone: 352-742-4774 | SMS Support and Parts: 352-309-1147
 E-mail: support@versa-pak.net

TEXT 352-309-1147 for the best support in the industry!
 For support include any relevant pics of your installation.

Please wire your Versa-Pak system according to the wiring diagram and please keep it neat. We can't support an install that is not wired to the diagram or is too sloppy to see how it is wired.

Versa-Pak V8X Standard Features

Shifting and Compatibility	Automatic Operation
Works with most brands, bypass or non-bypass cylinders, 1 or 2 coil valves, stationary, self-contained, apartment style or MPT style compactors. Must have 120VAC Outputs!	Auto Count (auto start when door closes)
Timer Shift (default), Pressure shift optional	Photo Eye Operation with Timer Start back up if Eye Too Long is triggered. This is helpful if eye is out of alignment or dirty.
Smart Shift feature shifts direction after deadhead for 2 secs	Auto Timer Operate with High and Low Volume Timers
Pressure Switch (optional but needed for Smart or pressure	ANSI 20 second delay with Warning Light and Horn
	Auto Operate Timer (Set time of day for Auto Operate)
	Ready to Run Auto Light
Works with inverter and has separate output for monitor.	Special Features
Has separate "Starter" output for inverter with monitor	Mail-Box Operate (Ram shifts into REVERSE when door opens)
Limit Switch Shift	Ram Stop Forward
Forward button (momentary)	Hold to Run
Productivity and Fullness	Q8 available for deodorizer motor.
Multi Cycle	Start in reverse after cycle is interrupted (Optional)
Many Cycles (press START 3x in 3 secs to run extra cycles)	Normal Off Hand or Driver's Switch (Optional Wiring)
Part Full Light with counter (flashing)	Several coil delay timers to customize the way your ram cycles
100% Full Shut Off with Light (solid)	Tech Features
Separate output for 100% light (Optional)	Operation Screens show errors, inputs, outputs, parameters
Errors (Protects Equipment)	Error and Troubleshooting Screens
Run Too Long Timer	Forward and Reverse Timer Setting Assist (pressure shifting cylinder)
Pressure Too Long Timer	Use PLC Buttons to START and STOP compactor
Photo Eye On Too Long Timer and Light	Front facing terminal blocks and disconnect terminal block.
Low Oil Input (Closed when oil is full)	Everything is labeled and has onboard instructions
Overload Tripped Input	Hour and Cycle Meter
All Errors have light & show on screen indicating problem	Smart Phone support- Talk, SMS, Email, Videos

For any Auto Operation the clock must be set. If the compactor is down for 2 weeks or so it will have to be reset.

Set Clock

Clock must be set for Automatic Operation. From the main screen:

▼ | ESC | Setup | OK | Clock | OK | Set Clock | OK (if you don't see "Clock" in this screen go to next section)

Set time (24hr format so 1pm is 13:00) then press ► to scroll to date. YY-MM-DD. Day of week is corrected. OK

Set S/W time. If the location of the install follows Daylight Savings Time, set S/W Time for US2. Otherwise, don't set.

Press ESC once to Setup menu and go down to Switch to OP and click OK. This locks others out of the PLC and prevents deletion of the program. To get back in Password is LOGO. ESC back to date screen and program messages will appear in a few seconds.

To get to Parameters after setting clock go to Program | OK | Set Parameter | OK

To get to Parameters from main screen– press ▼ then ESC | Program | OK | Set Parameter | OK

Set Clock from Operate Mode (if you don't see "Clock" in Setup screen)

Switch to ADMIN | OK | LOGO (use ▲ and ► to enter password) | OK | Setup | OK | Clock | OK

Set time (24hr format so 1pm is 13:00) then press ► to scroll to date. YY-MM-DD. Day of week is corrected. OK

Set S/W time. If the location of the install follows Daylight Savings Time, set S/W Time for US2. Otherwise, don't set.

Press ESC once to Setup menu and go down to Switch to OP and click OK. This locks others out of the PLC and prevents deletion of the program. To get back in Password is LOGO. ESC back to date screen and program messages will appear in a few seconds.

To get to Parameters after setting clock go to Program | OK | Set Parameter | OK

To get to Parameters from main screen– press ▼ then ESC | Program | OK | Set Parameter | OK

Instruction Decal

Our control system PLC has a white decal on it with useful information for quick reference.

ESC + ◀ to START compactor | ESC + ▶ to Stop
Parameters - ▼ then ESC / Program / Set Parameter

From Parameters, press ESC repeatedly back to
Date Screen then wait or ▲ to get to Messages Screens

Press ESC + ▲ or ESC + ▼ to scroll screens

Versa-Pak V8X by PSI Waste

Text SUPPORT to 352-309-1147

Setting Parameters

To get to Parameters from the main screen

Press ▼ then ESC / Program / Set Parameter

NOTE: If you get stuck on the screen that says "ESC+C... 9/9" and then has 4 arrows on it, press ► to get back to date screen.

You can press ◀ or ▶ to scroll through screens but they are mostly useless.

Each parameter is named for easy identification.

Use OK to enter the parameter, to indicate you want to change that parameter, and to save the new value.

Use ESC to get out of the parameter or if you change your mind after changing value but before you save with OK.

On Timers, you only set the T. Pay attention to the h (hours), m (minutes), and s (seconds) at the end of the times.

On Counters you only set the ON =

On Weekly Timers you would typically only set "D1 = [Days of Week]", "ON1 = [24hr time]" and "OFF1 = [24hr time]"

When done with Parameters ESC back to date screen, then wait or press ▲ to get to Messages Screens



Introduction

- The purpose of this manual is to provide the installer and owner with the necessary information to install our Versa-Pak Control system. Refer to equipment manufacturer's manual for additional information.
- PSI Waste shall not be responsible for conformity with any standards, codes, or regulations that apply to the combination of the features and options in the use of this product. The installer shall ensure, upon installation, the combination of features and options used are safe and appropriate for the application and operational environment.
- Installer and user shall read and understand ANSI Standard Z245.2 (Compactor Safety), OSHA 29 CFR, Part 1910.147 (Lock out/ Tag out), and the OEM compactor operation, maintenance, and installation manual.
- Must be installed by a qualified person.

Before installing

- Get familiar with the Versa-Pak system by studying the drawings and documentation included. It will not only save you time, but there are a lot of great features you'll want to use. Refer to it frequently.
- Words in [] are parameters.
- Words in ALL CAPS represent inputs (switches, etc.) and outputs (MOTOR STARTER, etc.)
- Make sure your control panel has a transformer that provides 120V power. Most compactors do.
- Make sure your outputs (valve, STARTER, etc.) are 120VAC. This control system is NOT compatible with 24VDC.
- There are compactors out there with two stage pumps, additional valves, etc. that may NOT be compatible with our control system. If you are not sure, take a few pics and email us. We'll steer you in the right direction.
- Please leave all documentation in the control panel. If you need extra copies, you can download them or call us and we'll send you a set, free of charge.

Message Screens

Message Screens help you understand what the compactor is doing and help you trouble-shoot issues. If the compactor is not wired according to the diagram provided, these messages may be inaccurate. Please carefully wire the compactor using our instructions, not your intuition. Tech support will be limited until properly wired.

Screens- Normal Operation

This message appears if I1, I2, I3 are all out at the same time. This would normally indicate the OFF/ON KEY SWITCH is off. If this message appears and the KEY SWITCH is turned on then check wiring, junction boxes, contact block, and all wire connections. Also, it may be that a maintenance door is open, DRIVER'S SWITCH is off, or E-STOP is pressed, and OIL IS LOW, and a FEED DOOR is open at the same time. (Or a connection to one of those switches). This message may also show if the power unit is connected to 208/240V, and the transformer is wired for 480V. Check your voltage at terminal 2. It should be around 120VAC.

```
Key Switch maybe
off. If not chec
connections,
contacts & term
2&3. Check for
Lo volt on trans
```

This message will appear if:

E-STOP is pressed, or OPTIONS installed between 3-4 or 4-5, are open. Check for power on those terminals. The device connected to the last terminal with power and the first terminal without power is the issue.

```
Check E-Stop and
options includ-
ing driver swtch
maintenance door
wire connections
terminals 4,5&7
```

If the oil level is low and an OIL LEVEL SWITCH is wired into I2, this message will appear. If the oil is full, check connections between the switch and 3 and I2. If connections are good, the switch may be set incorrectly or may be defective.

```
Oil level shows
low. Check Oil
level, oil level
switch.
Terminals 3 & I2
Reset w/ EStop
```

If this message shows, a FEED DOOR is open, or INTERLOCK CONNECTOR to compactor is not connected, or INTERLOCK is bad, or there is a bad connection.

```
E-Stop and/or
keyswtch both OK
Feed Door Open
or not connected
or maybe bad.
```

Once the compactor is running this screen will appear. It shows the status of the MOTOR, direction of travel with remaining time in that direction, if the pressure switch is on, and current cycle count.

```
Motor On
Forward    55:02s
           00:00s

Pressure Not ON
Cycle      1
```

This screen shows the REVERSE button is pressed, or water is causing a false input, or the REVERSE button has a normally closed contact or there is a wiring error.

```
Reverse button
is on.
If this is error
check for water,
wiring, or bad
or N.C. contact.
```

Error Screens

There are several error screens. This error shows the MOTOR OVERLOAD is tripped. Other errors are "Compactor is full or jammed", "Compactor ran too long", "Pressure switch was on too long", "Photo eye was on too long". See error section for more information. Once the error is cleared, the STOP BUTTON must be pushed and released to reset the PLC.

```
Motor Overload
is on. Have qua-
lified person
reset overload,
check for issues
Reset w/ E-Stop.
```

Other Screens

There are other screens that you can get to using the buttons on the front of the PLC. Press ESC and ▲ at the same time to scroll through the screens. You can scroll back down by pressing ESC and ▼ at the same time. These screens will stay on for 60 secs after the last time you press up or down. To get back to the Welcome screen just scroll all the way down. NOTE: Be sure to press ESC first when going down since ▼ by itself gets you out of the programmed screens. You can hold ESC and click ▲ and ▼ to scroll back and forth. Also, don't rush while cycling through the screens or the PLC will not recognize the press or release of the button.

This screen shows which inputs are ON and OFF. I1, I2, and I3 must be on to start a cycle. This is a good screen to be on to set the PRESSURE SWITCH or just get a clear view of input status.

```
I1 is ON
I2 is ON
Feed Door is ON
Start is OFF
Reverse is OFF
Eye is Not Block
```

This screen shows which outputs are ON and OFF. It shows a clean view of output status and differentiates warning light/ horn, part full light, and 100% full status.

```
Motor is ON
Forw Coil is ON
Rev Coil is OFF
Warn Light OFF
Part Full OFF
100% Full OFF
```

This screen shows the set values of basic parameters. These values can be changed in this screen by holding down the ESC button for a few seconds. Once in EDIT mode (black box highlights one of the parameters) the screen will remain active. When ready to exit the screen, press ESC again.

```
Forw Time 60:00s
Rev Time 60:00s
MultiCycle 2
ManyCycles 4
Part Full 90:50s
100% Full 92:00s
```

This screen shows the current settings of Auto Operate and the current time of day on the PLC. You'll want to check the accuracy of the time. You can also change the door count setting (current value is on the left (0), setting is on the right (900003)).

```
Auto CntMo 09:05
Auto Operate
ON00:00-OFF00:00
Door Count is
0 of 900003
ANSI Delay20:00s
```

This screen shows how many hours and cycles the compactor has run since the last time these have been reset. If the PLC loses power for 2-3weeks these will be reset.

```
Hours 0
Cycles 0
```

Get Time Settings for Pressure Shifting Cylinders

If your cylinders are pressure shifting type (When the cylinder hits the end of the stroke you reach full pressure) you can easily get your exact [Forward Time] and [Reverse Time] by following the instructions below.

- Install the Versa-Pak V8X control system.
- Test controls for proper operation.
- Set PRESSURE SWITCH.
- Set relief valve.
- Make sure all air is out of hydraulic system.
- Run compactor a few times.
- Navigate to timer setting screen (See instructions in previous section).
- Note the times. If three digits format is X:XX. If 4 digits XX:XX.
- Hold the ESC button down for a few seconds. Set Forw Set and Rev Set.
- Test run compactor. It should make a full stroke without deadhead. An adjustment of 0.10 or so may be needed.
- If you do this multiple times and get varying results (more than 0:10 for a self-contained unit) you may have air in the system or a mechanical issue. Check oil level, suction screen, suction pipe, bypassing cylinder(s), pump, relief valve, directional valve.

```

PSI Shift Cylin?
RunCycles,SetTim
Forw Cycl      0
Forw Set 60:00s
Rev Cycle      0
Rev Set 60:00s
    
```

Inverters

If you will be using a contactor or relay to start the inverter:

- Wire that contactor or relay as you would a STARTER using the brown wire from Q1 2 and white wire from 1. Get rid of the Black and Brown wires labeled 97 and 98.

If you are not using a separate contactor or relay:

- Remove jumper "Inverter" from Q1 1 to Control Power (I7)
- Put the two control wires coming from the inverter to Q1 1 and Q1 2. Remove 7 and I8 wires if not used.

NOTE: 7 and I8 Overload wires may be wired to alarm N.O. dry contact on inverter. Check inverter instructions.

NOTE: Q8 can be used for monitor starter input. See page 15.

Terminal Blocks

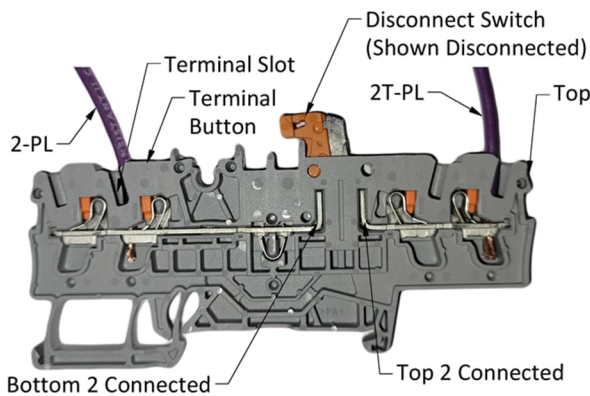

Terminal Block Disconnect

Terminal Block 2T & 2 (first hot terminal block that transformer and PLC hook to) has a switch to disconnect control power to terminal 2 and the rest of the terminals. This is useful if the power disconnect is not nearby. Only use this switch if the panel can be safely worked on with the main power on. Test terminals 2 + to make sure the power is disconnected. The top two terminals are the transformer and PLC so the PLC will stay lit. The message screen will show the KEY SWITCH is turned off.

NOTE: If someone wired the Transformer to a different terminal, this would not work! Never trust the guy before you!

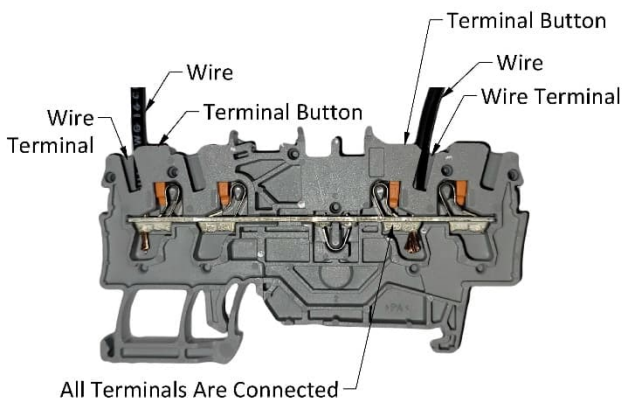

Standard Terminal Block

The standard terminal blocks are connected top to bottom, so all four wire positions are all the same. Push the orange buttons to release the wire slot to insert or remove the wires. There are also 3 black jumpers from 2-3, 3-4, 4-5 in the center of the terminal strip. To remove these wires just pull on the jumper. The light gray bar jumpers stay put.

Basic Operation (Default Options)

Press Start

Compactor will cycle forward for FORWARD TIME then shift to reverse for REVERSE TIME.

If MULTI CYCLE and MANY CYCLES have been reached compactor will shut down.

If MULTI CYCLE and MANY CYCLES have not been reached compactor will continue with another cycle.

If photo eye is connected to #7 and photo eye senses trash is present, even if [Auto Operate] is not on, compactor will continue with another cycle.

If, during forward stroke, PRESSURE SWITCH senses pressure for SMARTSHIFT F time compactor will shift to reverse.

If, during reverse stroke, PRESSURE SWITCH senses pressure for SMARTSHIFT R time compactor will shift to forward or shut off depending on cycle count.

Basic Parameters

Parameter Name	Parameter Default	Function	Notes
Forward Time	60:00s	Ends FORWARD stroke. Set for the time it takes the ram to go from all the way back to all the way forward.	For pressure shifting type cylinder, get times using above procedure. Timers can be set down to the 1/100 th of a second so no need to bottom out.
Reverse Time	60.00s	Ends reverse stroke. Set for the time it takes the ram to go from all the way forward to all the way back.	For bypass type cylinders allow the cylinders to bottom out for a fraction of a second.
Multi Cycle	2	Causes compactor to run multiple cycles.	
Many Cycles	3	Causes compactor to run multiple cycles if the START button is pressed 3 times in 3 seconds.	If START button is pressed 3 times within 3 seconds, compactor will run this many cycles. Useful for trash valet and cleaning up a lot of trash.

Fullness Timers

Feature Description	Parameter Default/ Suggested	Activate Feature	Notes
Part Full	90.50s 00.50s	Turns on full light (Q4) but compactor continues to operate as usual. Light is reset by E-STOP, maintenance door, KEY SWITCH, or main power. Requires pressure or amp switch. Set at least 150psi below relief setting.	Timer will ignore first stroke after cycle is interrupted. Part full feature flashes Full Light (Q4) but compactor will continue to operate normally. 100% Full feature will cause the full light to be solid and shuts down operation. Reset both with E-STOP, KEY SWITCH, etc.
PartFullCnt	1 / 5	Sets the number of times Part Full timer has to time out before turning on the Part Full light. Reduces false indications.	
100%Full/Jam	92.00s 02.00s	Turns on full light (Q4). Shuts down compactor immediately. Reset by E-STOP, maintenance door, KEY SWITCH, or main power. Requires PRESSURE SWITCH. Set at least 150psi below relief setting.	

Smart Shift Timers

Parameter Name	Parameter Default	Function	Notes
Smart Shift F	02.10	Shifts compactor from FORWARD to REVERSE if PRESSURE SWITCH detects pressure for time setting.	Important for pressure shifting cylinders. Prevents excessive deadheading when cycle is interrupted.
Smart Shift R	04.00	Shifts compactor from REVERSE to FORWARD if PRESSURE SWITCH detects pressure for time setting.	Important for pressure shifting cylinders. Prevents excessive deadheading when packing out. This may cause an issue (especially in colder weather) if the back pressure is high in reverse. If so, you can shorten and/or oversize hoses. Or increase setting.

Note: You can make unit pressure shifting if desired. Set [Forward Time] and [Reverse Time] higher than forward and reverse strokes can take (with Hi Lo pump or regen, set them much higher). Set Smart Shift F and Smart Shift R to 00.25. Do not set below 00.25 (1/4 Sec) or it may cause a glitch. Also, set your full times .25 higher to account for this time.

Directional Valve Time Delay

Parameter Name	Parameter Default/ Alt	Function	Notes
Coil Delay F	00.10/01.00	Delays shift of forward solenoid at beginning of cycle and between REVERSE to FORWARD. Useful when running a unit with a forward/reverse starter instead of a directional valve.	Requires open or tandem center valve. Allows motor to start under a no-load condition. Ram Stop Forward- If [Stop R-9 F-0] is set at "0", this delays REVERSE coil at start and during cycle.
Coil Delay R	00.10/01.00	Delays shift of REVERSE solenoid when pressing REVERSE button. Useful when running a unit with a forward/reverse starter instead of a directional valve.	Requires open or tandem center valve. Allows motor to start under a no-load condition. Note: If moving FORWARD and the REVERSE button is pressed, valve will shift to center for time set before shifting to REVERSE. Ram Stop Forward- If [Stop R-9 F-0] is set at "0", this delays Forward coil when Forward button is pressed.
Delay F to R	00.10/01.00	Delays shift of REVERSE solenoid when shifting from FORWARD to REVERSE. Useful when running a unit with a forward/reverse starter instead of a directional valve.	Requires open or tandem center valve. Ram Stop Forward Mode- If [Stop R-9 F-0] is set at "0", this timer delays Forward coil when shifting from REVERSE to FORWARD.
Rev Coil Off	00.00/01.00	Delays the REVERSE coil after cycle stops.	Useful with bypass cylinders to prevent ram from creeping forward after cycle. Setting this time on pressure shifting cylinders will cause a pressure spike at the end of the cycle.

Maintenance Cycle Counter

Parameter Name	Parameter Default	Function	Notes
Cycles Maint	900000	Notifies user the compactor needs to be PM'd and counter needs reset. Causes Q4 to blink rapidly and message to show on screen.	Message is: Compactor is Ready to Start. ***Maintenance Required!!!*** Call Your Service Company. To reset the timer, hold ESC + ▼ for 5 seconds.

Errors

Versa-Pak V8X shuts down the compactor if it detects certain errors. In this event the error will be displayed on screen of the PLC. Read the screen before clearing the error and correct the issue before continuing to operate compactor. To clear error either press the E-STOP, turn KEY SWITCH off, or turn power off to the unit and back on.

Error Parameter	Common Causes	Possible Solution
Oil Level Low	Oil level is low OIL LEVEL SWITCH is out of adjustment OIL LEVEL SWITCH is bad Bad connection between Terminal Block 3 and I2	Top off oil, check for and repair leaks. Adjust OIL LEVEL SWITCH Replace OIL LEVEL SWITCH Repair wiring
Motor Overload	This error is caused by the overload relay on the STARTER tripping Overload setting is wrong	Check Motor issues section of this manual for solutions Set overload setting correctly
100% Full/ Jam	The compactor is full Something is blocking the ram in the charge box. Timers are set incorrectly	Empty compactor Clear the hopper and watch the ram cycle. Set timers correctly
Ran Too Long (11:00m)	Multi Cycle is set too high Run Too Long is set too low PHOTO EYE is dirty or is out of adjustment START button contacts have moisture START wire shorted to power	Correct timer setting Correct timer setting Clean and adjust PHOTO EYE, reflector Change out contact, resolve moisture issue. Repair short
PSI Too Long (60:00s)	PRESSURE SWITCH has been on too long during the run time. Compactor was run with hoses disconnected QD's are bad PRESSURE SWITCH is out of adjustment PRESSURE SWITCH is bad Oil is too thick or too cold Hoses are too long	Check time setting. Should be 60.00s Connect hoses Replace QD's Adjust PRESSURE SWITCH Replace PRESSURE SWITCH Use thinner oil or let oil warm up Use larger diameter hoses or shorten them in length.
Eye Too Long (10:00m)	See PHOTO EYE Section	
Compactor is Ready to Start. ***Maintenance Required!!!*** Call Your Service Company.	It's time for a PM of the compactor. See Maintenance Cycle Counter section.	[Maint Cycles] has reached the setting. PM Compactor. Reset the counter by holding ESC + ▼ for 5 seconds.

Other Errors and Issues

Start Button- The START button must be released by the end of the cycle or the compactor will not cycle again. So, if the start button contact has water in it the compactor may not start again until the issue is rectified.

"False inputs"- It is possible for the program to see an input but not indicate so or vice versa. In this case a voltage meter may show very low, or even zero voltage when testing. Often, in this case, using a voltage meter from terminal block 1 to the input in question will clear the error allowing normal operation. This is often caused by water in a contact block or junction box. Often, using a water displacement spray will correct the issue.

Two wire proximity switches or amp switches- Two wire prox switches will cause a constant false input. Amp switches (like the ones we sell for the older versions of Versa-Pak) will cause a false input when the amperage gets near the set value. We do not recommend using these. These issues are due to the switch needing power to operate, unlike most switches used on a trash compactor. The power needed to operate the switch exceeds the power needed to turn on the input.

Hold to Run

“Dead Man” or “Hold-to-Run” is a safety feature for a compactor without guarding. The operator must hold the START Button to keep the compactor running. At the end of the cycle the compactor will stop and will not start again until the START Button is release and pushed again. This prevents someone from tampering with the controls to bypass the safety feature.

Parameter Name	Parameter Default	Parameter Setting to enable Function
Norm-9Hold-0	90:00h	00:00h
Multi Cycle	2	1

Ram Stop Forward Operation

Ram Stop Forward is preferred by some locations as a safety feature especially when it is possible for someone to fall into the charge chamber. Also, it's a security feature for stores with chutes.

Parameter Name	Parameter Default	Parameter Setting to enable Function	Notes
Stop 9-R 0-F	90:00h	00:00h	Setting [Stop 9-R 0-F] to 00:00h causes ram to stop in the forward position. If this is set to Ram Stop Forward the REVERSE button will become the FORWARD button and FORWARD button (if used) will become REVERSE and the compactor will start in REVERSE. ***MB will not work if set for Ram Stop Forward

Mail-Box Operation

Mail-box operation is useful in chute applications with interlocked doors. In these applications bridging of the trash over the charge-box is common. Mail-box operation causes the ram to shift into REVERSE when the door is opened during the cycle. This will allow trash to fall into the void caused by the ram movement. If the door is shut before a. [Reverse Time] times out or b. the ram deadheads back and triggers the PRESSURE SWITCH, and [Multi Cycle] has not reached its count, the compactor will continue to cycle. If the [Reverse Time] times out or the ram deadheads in REVERSE and triggers the PRESSURE SWITCH, the cycle will be complete.

Safety Considerations

- Ensure site is safe and appropriate for Mail-Box operation.
- Feed door must meet the 84" rule: Feed height is minimum 42" and total distance from feed platform, up to ledge, then down to the closest moving part is 84".
- This rule generally means the ram cannot be touched by an average height man standing flat-footed at the feed area.

Parameter Name	Parameter Default	Parameter Setting to enable Function	Notes
Norm-90 MB-0	90:00h	00:00h	Causes the ram to shift into REVERSE when the door is opened. ***MB will not work if set for Ram Stop Forward

Start in Reverse

ANSI requires this feature to be enabled if the compactor does not have a REVERSE button.

Parameter Name	Parameter Default	Parameter Setting to enable Function	Notes
StrtRv 9N 0Y	90:00h	00:00h	If set 00:00h Initial start or if the cycle is interrupted in any way, the compactor will start in reverse the next time it starts regardless of the means of starting (pressing the START button or automatically starting or using the PLC BUTTONS). Starting the compactor after a full cycle was completed successfully will cause the compactor to start forward.
Rev Alw 9N 0Y	90:00H	00:00h	Causes the compactor to always start in reverse even when not interrupted.

NOTE: If you switch a feature back and forth and the feature doesn't work right, shut power off then back on to reset.

Auto Door Count

[Door Count] starts the compactor automatically when the FEED DOOR (wired 3-6, and 6-13) is opened and closed the number of times set on the parameter [Door Count] ON= line. Loss of CONTROL POWER, KEY SWITCH, E-STOP, REVERSE and START all reset the current count value to 0.

Safety Precautions

- Ensure a minimum feet height of 42"
- Ensure site is safe and appropriate for Auto Count operation.
- Access to the charge box should be limited and must be interlocked.
- With few exceptions that rarely apply- YOU MUST INSTALL A WARNING LIGHT AND BUZZER and delay start for 20secs according to ANSI standards!
- Install E-STOPS at every point of entry.
- Install all safety decals including "This Machine Starts Automatically!"

Enable Auto Count

- Install warning light to terminals 1 (Neutral) and Q6 and horn to terminals 1 (Neutral) and Q5
- Clock must be set for Automatic Operation. ▼ | ESC | Setup | OK | Clock | OK | Set Clock | OK
- Set S/W time. If the location of the install follows Daylight Savings Time, set S/W Time for US2.
- Set [Auto Operate] including days of the week
- Make sure your FEED DOOR is wired as "Feed Door". DO NOT wire in series to the E-STOP. See drawing.
- Check [ANSI 20sec] to ensure proper setting.
- Set [DOOR COUNT]. See "Setting Parameters" section of this manual.
- Set additional options as desired.

Parameter Name	Parameter Default	Suggested setting to enable Auto Operation	Notes
Auto Operate	D1 = MTWTFSS ON1 =00:00 OFF1=00:00	Auto Operate 24/7 D1 = MTWTFSS ON1 =00:01 OFF1=00:00 Operate 6am-10pm D1 = MTWTFSS ON1 =06:00 OFF1=22:00	Enables Auto Operate during certain times and days. The default time will not allow auto operation of any kind because the times are the same. Setting ON1=00:01 and OFF1 to 00:00 will allow auto operation any time of the day (except for 12:00am to 12:01am). The alternative example is 6:00am – 10:00pm (24hr clock so 22:00), 7 days a week. The compactor will run in auto from 6am-10pm every day. This is useful if operating the compactor disturbs residents at night. Manual START is always enabled.
Door Count	900003	000003	Sets number of door closes to initiate auto-count feature. This is reset when the ram reverses. So, if the door is opened during the first forward stroke it will start again on the next door close.
ANSI 20 Sec	20:00s	20:00s	Delays the automatic start of the compactor.

Note: If compactor has no power for more than 15 days or so, you may have to reset clock.

Note: If you choose not to use the warning light and buzzer you should set [ANSI 20sec] to "00.00" and [Warn 0-Y 9-N] to "9".

Note: To cancel Auto Count Set [Auto Operate On1 and Off1] to "00:00"

Note: After disabling [Auto Operate], Set [Door Count] to 900002. (The only thing that matters is the first 9)

Auto Photo Eye

Safety Precautions

- Photo eyes are not desirable in most situations. They are best used in applications where access to the charge chamber is limited (like in an apt style unit with limited access and a small door).
- Ensure a minimum feed height of 42"
- Ensure site is safe and appropriate for PHOTO EYE operation.
- Access to the charge box should be limited and must be interlocked.
- YOU MUST INSTALL A WARNING LIGHT AND BUZZER and delay start for 20secs according to ANSI standards!
- Use only Maintained (Push/Pull) Emergency Stop buttons. Install E-STOPS at every point of entry.
- Install all safety decals including "This Machine Starts Automatically!"
- We recommend using the ANSI Auto Mode (pg14) input for safe operation.

Installing Eye

NOTE: We suggest buying an electric eye from us so that we can support you better. If you buy one on your own, we will not be able to fully support the install of the eye. We'll help you if we can though.

- Install warning light to terminals 1 (Neutral) and Q6 and horn to terminals 1 (Neutral) and Q5
- Make sure [ANSI 20secs] is set at "20:00" (Factory setting, ANSI delay start)
- Clock must be set for Automatic Operation. ▼ | ESC | Setup | OK | Clock | OK | Set Clock | OK
- Set S/W time. If the location of the install follows Daylight Savings Time, set S/W Time for US2.
- Wire the N.O. PHOTO EYE contact to #7 and I6 (see schematic)
- Wire the PHOTO EYE power to terminal blocks #7 (hot) and #1 (neutral)
- If you bought a Banner Eye from PSI Waste- Brown goes to #7, Blue goes to #1, Yellow goes to #7, Black goes to I6, White gets a wire nut.

Parameter Name	Parameter Default	Suggested setting to enable Auto Operation	Function	Notes
Auto Operate	D1 = MTWTFSS ON1 =00:00 OFF1=00:00	Auto Operate 24/7 D1 = MTWTFSS ON1 =00:01 OFF1=00:00 Operate 6am-10pm D1 = MTWTFSS ON1 =06:00 OFF1=22:00	Enables Auto Operate during certain times and days. The default time will not allow auto operation of any kind because the times are the same. Setting ON1=00:01 and OFF1 to 00:00 will allow auto operation any time of the day (except for 12:00am to 12:01am). The alternative example is 6:00am – 10:00pm (24hr clock so 22:00), 7 days a week. The compactor will run in auto from 6am-10pm every day. This is useful if operating the compactor disturbs residents at night. Manual START is always enabled.	
Eye Delay	05:00s	05:00s	Delays starting compactor when eye is blocked.	Prevents compactor from starting every time trash passes eye.
ANSI 20 Sec	20:00s	20:00s	Delays start for ANSI required 20 secs.	If eye is cleared before the compactor starts, the start sequence is reset.
Eye Too Long	10:00m	10:00m	Prior to V8.4: Shuts compactor down if eye is on too long. V8.4: Turns off the eye input only. Compactor can still operate by other means, manual or auto. All V8 Versions: Q7 lights up solid.	Set higher than eye is likely to be blocked. Set Run Too Long higher than Eye Too Long. Reset with E-STOP, KEY SWITCH, or main power. V8.4 and later: You can use the Auto Timer to run the compactor every hour or so if the eye is out of adjustment or is dirty. If you choose this, set Auto Operate timer to prevent operation overnight.
EyeBypasTimr	01:00h	01:00h	Automatically starts compactor every hour if the eye gets blocked.	Only works if EyeTooLong is on. If eye is bad, set LoVolumTimer until eye is repaired.

Note: If compactor has no power for more than 15 days or so, you may have to reset clock.

Note: To cancel Auto Eye, disconnect PHOTO EYE.

Auto Timer Start

Auto Timer starts the compactor on interval [LoVolumTimer] during [Auto Operate] time period. If [Hi Volume AM] and/or [Hi Volume PM] are set, then compactor will start at interval [HiVolumTimer] during that period. At the beginning of each start the WARNING LIGHT/ HORN output will come on to warn the compactor is about to start.

Safety Precautions

- Ensure a minimum feed height of 42"
- Ensure site is safe and appropriate for Timer Auto Operation.
- Access to the charge box should be limited and must be interlocked.
- With few exceptions that rarely apply- YOU MUST INSTALL A WARNING LIGHT AND BUZZER and delay start for 20secs according to ANSI standards!
- Use only Maintained (Push/Pull) Emergency Stop buttons. Install E-STOPS at every point of entry.
- Install all safety decals including "This Machine Starts Automatically!"
- Install warning light to terminals 1 (Neutral) and Q6 and horn to terminals 1 (Neutral) and Q5
- Make sure [ANSI 20sec] is set at 20:00 (Factory setting, ANSI delay start)
- We recommend using the ANSI Auto Mode (pg16) input for safe operation.

Enable Auto Timer

- Clock must be set for Automatic Operation. ▼ | ESC | Setup | OK | Clock | OK | Set Clock | OK
- Set S/W time. If the location of the install follows Daylight Savings Time, set S/W Time for US2.

Parameter Name	Parameter Default	Suggested setting to enable Auto Operation	Notes
Auto Operate	D1 = MTWTFSS ON1 =00:00 OFF1=00:00	Auto Operate 24/7 D1 = MTWTFSS ON1 =00:01 OFF1=00:00 Operate 6am-10pm D1 = MTWTFSS ON1 =06:00 OFF1=22:00	Enables Auto Operate during certain times and days. The default time will not allow auto operation of any kind because the days of the week are. The alternative example is 6:00am – 10:00pm (24hr clock), 7 days a week. Compactor will run in auto from 6am-10pm every day. Setting ON1=00:01 and OFF1 to 00:00 will allow auto operation any time of the day. Note that the "ON1=" time is when the timer starts timing. So, if [LoVolumTimer] was set for 30:00m the compactor will not start until 06:30. Manual START is always enabled.
LoVolumTimer	T=99.59h	T=60:00m	This time represents how often the compactor will run from the time [Auto Operate] is enabled until compactor starts or from the time the compactor stops to the time it starts again during the [Auto Operate] period.
Hi Volume AM	D1 = MTWTFSS ON1 =00:00 OFF1=00:00	D1 = MTWTFSS ON1 =07:00 OFF1=10:00	If a compactor has high volume and low volume times during the day, such as an apartment complex, you can set the compactor to cycle more often during those times. [HiVolumTimer] will be enabled during these time periods.
Hi Volume PM	D1 = MTWTFSS ON1 =00:00 OFF1=00:00	D1 = MTWTFSS ON1 =17:00 OFF1=19:00	
HiVolumTimer	T=99.59h	T=30:00m	This time represents how often the compactor will run from the time [Hi Volume AM or PM] is enabled until compactor starts or from the time the compactor stops to the time it starts again during the [Hi Volume AM or PM] periods.
ANSI 20 Sec	20:00s	20:00s	Delays start for ANSI required 20 secs.

Note: If compactor has no power for more than 15 days or so, you may have to reset the clock. This may require a password to get into ADMIN. Call us for Password.

To Cancel Timer Auto Operate: Set [Auto Operate On1 and Off1] to "00:00" and Lo and Hi Volume AM/PM to "ON1=00:00" and "OFF1 = 00:00". Set [LoVolumTimer] and [HiVolumTimer] to 99.59h.

Man/Off/Auto

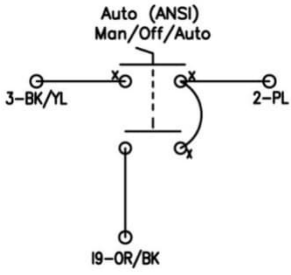

Man/Off/Auto

If you are using a Man/Off/Auto key switch you must set [AutoKey9Y 0N] to 00:00. Also consider the state of [ANSI 9=1 0=2]. The default is ANSI 1. See chart below for more information.

Parameter Name	Parameter Default	Suggest Setting to Enable Feature	Function	Notes
AutoStrtHold	00.00s	20:00s	If set when using ANSI Auto Mode, to start Auto Start Circuit operator must hold START for the time setting.	Required by ANSI when auto starting a compactor that is part of a multi-piece processing system (e.g. compactor fed by conveyors).
ANSI 9=1 0=2	ANSI Mode 1 (Default) 90.00h		ANSI Auto Mode is the preferred method of operating a compactor automatically with photo eye (pg14) or on time (pg15). When using ANSI Mode 1 (default) the START button must be pressed to initialize the Auto Mode. If any of the following occur, the automatic control circuit will need to be re-initialized: <ul style="list-style-type: none"> • E-Stop pressed, or maintenance door opened • Reverse or Forward button pressed • Error occurs or compactor reaches 100% full. • Switch is switched to Off or Man • Feed door is opened (unless [FeedRst9Y-0N] is set to 00.00) 	
	ANSI Mode 2 00.00h			
FeedRst9Y-0N	90.00h		If set to 90.00h, opening of a Feed Door will require Auto Mode to be reset. The start button will need to be pressed to reset Auto Mode. Setting to 00.00 will prevent the opening of a Feed Door from requiring Auto Mode to be reset. This violates ANSI so other means will need to be taken to ensure safety.	
Q8Ready 0Y9N	90:00h		If set to 00:00 and the compactor is ready to run in auto, and using I9 Auto input, Q8 will turn on and stay on as long as the compactor is ready to start and auto operate is on. Not compatible with Q8Strt 0Y9N or Q8 Full 0Y9N. See Q8 Operation on pg 15. Use this with ANSI-2, Man Off Auto Switch.	

NOTE: If you switch a feature back and forth and the feature doesn't work right, shut power off then back on to reset.

Normal/Off/Jog

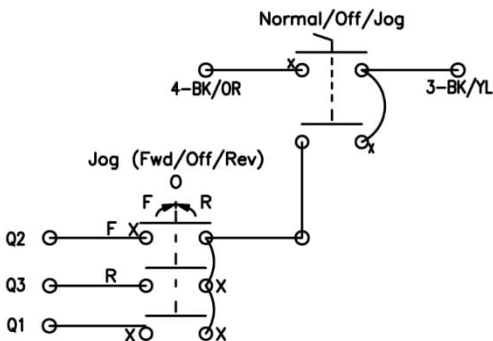

Normal/Off/Jog

Can be used as a driver's switch or for manual operation. Forward and Reverse are momentary. This switch, as wired, will bypass Feed Doors and the E-Stop, Maintenance Doors, or the Low Oil switch. It will NOT bypass the Off/On Key Switch. To bypass the Off/On Key Switch exchange terminals 3 and 4 on this switch with 2 and 3 on Off/On switch.

Other Inputs and Outputs

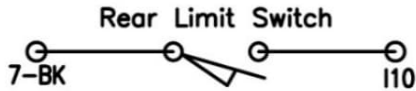

Rear Limit Switch

V8X is compatible with Rear and/or Front Limit switches. Be sure to set appropriate timer high enough so the ram will hit the limit switch before [Reverse Time] runs out.

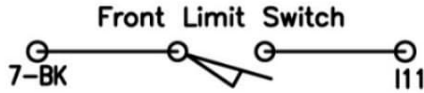

Front Limit Switch

V8X is compatible with Rear and/or Front Limit switches. Be sure to set forward timer high enough so the ram will hit the limit switch before [Forward Time] runs out. If you have a high/low pump or regen system, be sure to set the timer much higher.

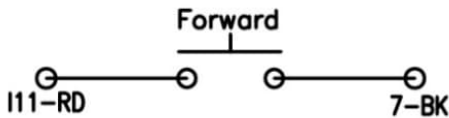

Forward Jog

FORWARD is a momentary switch that will jog the ram forward. It works exactly like REVERSE. In RAM STOP FORWARD mode it becomes REVERSE.

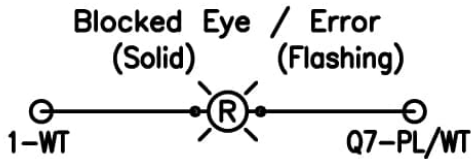

Blocked Eye (Solid) / Error (Flashing)

Light lights up when the eye is blocked for [Eye Too Long] time (10-mins Default). If there is an error, light will flash.

Q8 Operation- Monitor "Starter Coil Wire" or Separate 100% Full Light or Ready to Run in Auto Light

Parameter Name	Parameter Default	Suggested Setting to Enable Feature	Notes
Q8 Strt 0Y9N	00:00h To turn off (if using a feature below) set to 90:00h	00:00h	If you are using Q1 to directly start an inverter and need a 120VAC starter input for a monitor, enable this feature to use Q8 output for Monitor 120VAC input. Wire monitor starter coil wire to Q8-2 (right screw). Not compatible with Q8 Full 0Y9N
Q8 Full 0Y9N	90:00h	00:00h	Enable this feature to use Q8 output for 100% full light. Not compatible with Q8Strt 0Y9N.
Q8Ready 0Y9N	90:00h	00:00h	If set to 00:00 and the compactor is ready to run in auto, and you are using I9 (Auto) Q8 will turn on and stay on as long as the compactor is ready to start and auto operate is on.

NOTE: If you switch a feature back and forth and the feature doesn't work right, shut power off then back on to reset.

* Indicates optional components. If option is installed, remove the corresponding jumper from the center jumper rail.
 ** Indicates optional components. Omit connections if not installed.
 *** CAUTION: To reduce the risk of fire, replace only with UL listed fuses of the same type and rating.
 **** Use for options such as driver's switch, maintenance doors, or additional E-Stop. If option is installed, remove the corresponding jumper from the center jumper rail.
 ***** If Reverse button is not used, enable Strt Rv 9N 0Y or Rev Alw 9N 0Y to cause machine to start in reverse. See Operation Manual.

Field Wiring: Use copper wire only.

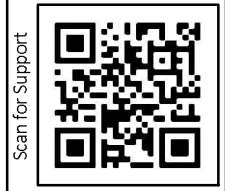

Scan for Support

Main Disconnect
 Main disconnect/branch must be supplied by installer. Refer to fuse and breaker chart and local codes.

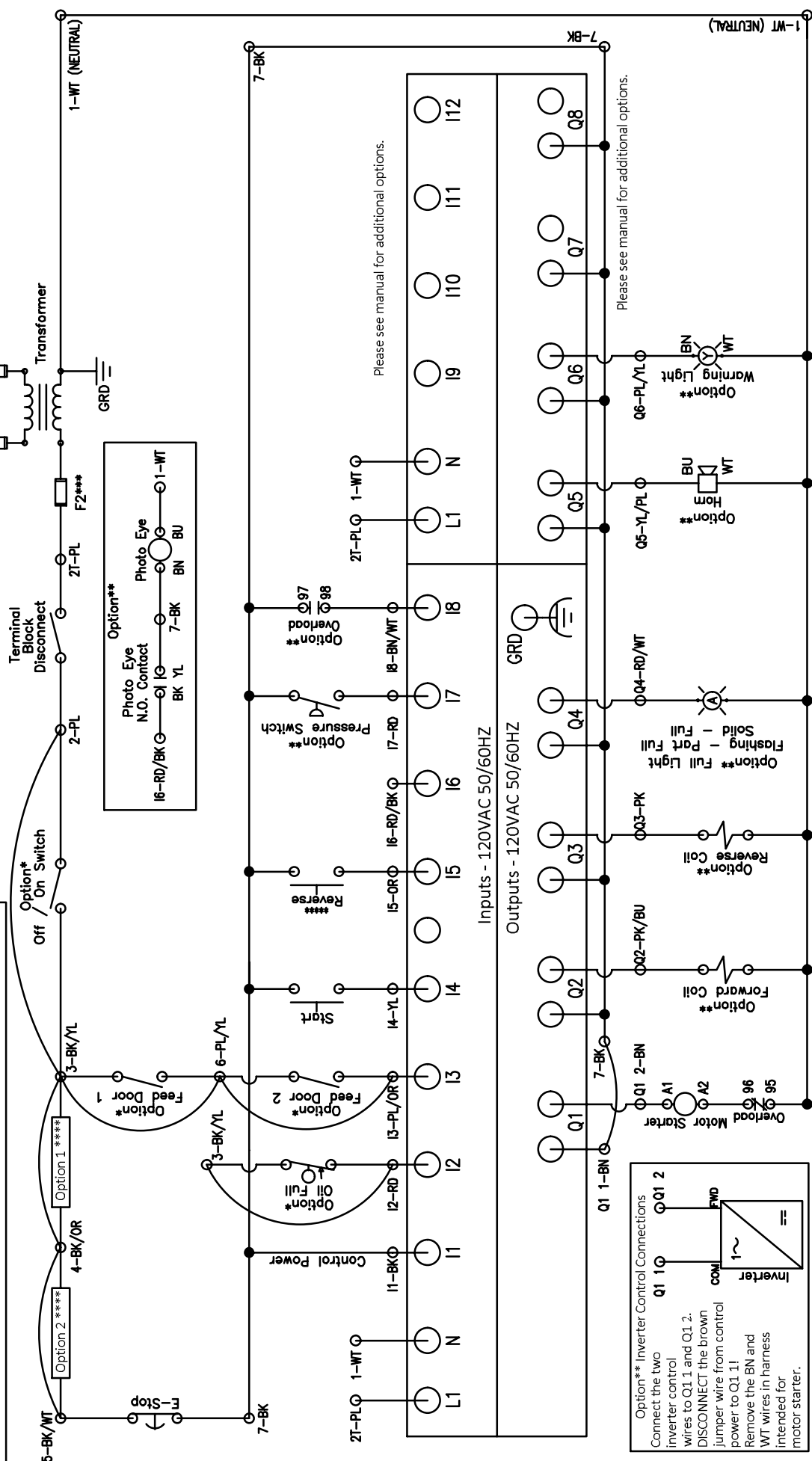
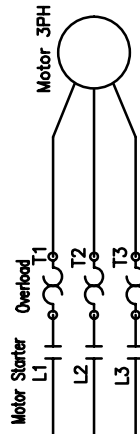

	Title: Versa-Pak 8X, Standard DWG #: VP8X01	Date: 11/8/22 Drawn: CB
	Color Code: GR - Green WT - White PL - Purple BK - Black BN - Brown PK - Pink BU - Blue YL - Yellow OR - Orange RD - Red	

Panel Manufactured by PSI Waste Equipment Services, Inc. 31130 Industry Drive, A, Tavares, FL 32778 Support, downloads, and videos: www.versa-pak.net or call 352-742-4774 Opt 4