

# Versa-Pak V5 CEX

By PSI Waste Equipment Services, Inc.  
Versa-Pak V5 CEX SUPPORT [www.versa-pak.net](http://www.versa-pak.net)  
Phone: 352-742-4774 Fax: 407-992-9389  
E-mail or Text: [support@versa-pak.net](mailto:support@versa-pak.net)

## Introduction

- The purpose of this manual is to provide the installer and owner with the necessary information to install our Versa-Pak Control system. Refer to equipment manufacturer's manual for additional information.
- PSI Waste shall not be responsible for conformity with any standards, codes, or regulations that apply to the combination of the features and options in the use of this product. The installer shall ensure, upon installation, the combination of features and options used are safe for the application and operational environment.
- Installer and user shall read and understand ANSI Standard Z245.2 (Compactor Safety), OSHA 29 CFR, Part 1910.147 (Lock out/ Tag out), and the OEM compactor operation, maintenance, and installation manual.
- If you are not fully qualified to install the Versa-Pak system safely, please stop and return it for a full refund!

## Installation

### Before installing

- Get familiar with the Versa-Pak system by studying the drawings and documentation included. It will not only save you time, but there are a lot of great features you'll want to use. Refer to it frequently.
- Spend a few minutes watching all our youtube videos at [www.versa-pak.net](http://www.versa-pak.net) . You'll learn a lot! Average video length is 3-1/2 mins. Videos are easy to watch on your smart phone too.
- Please do not leave your manual behind when heading out to install our control system in the field! If you do forget it, please go to [www.versa-pak.net](http://www.versa-pak.net) to download one. If you don't have a smart phone find a computer, download a manual, and print it out.
- Make sure your control panel has a transformer that provides 120V power. Most compactors do.
- There are compactors out there with two stage pumps, additional valves, etc. that may NOT be compatible with our control system. If you are not sure, take a few pics and email us. We'll steer you I the right direction.
- Please leave all documentation in the control panel. There is nothing worse than getting to a site and not having the info you need to make a simple adjustment or troubleshoot a problem. If you need extra copies you can download them or call us and we'll send you a set, free of charge.
- Our CEX version of Versa-Pak is slightly different than our standard version. The Schematic includes a "E-Stop Pushed Light" on the Emergency stop button that allows an operator to see the E-Stop is actuated. It also includes separate outputs for Warning Horn and Light and Full Light. This makes Auto Start features compatible with Full features. The CEX version is also wired with the terminals below the PLC since the PLC is much longer and there are more terminal blocks. Otherwise the two systems are the same.

### Install- PLEASE, DON'T FORGET YOUR MANUAL!

1. We have included a manual, schematic decal, motor data tag decal, wire ties, tie pads, screws, wire nuts etc. to ensure you can install the Versa-Pak system in a professional manner. Please do so.
2. Remove control system and terminal blocks. Leave only the transformer and starter.
3. Remove all wires from contact blocks on the control buttons.
4. Start button and reverse button should have (1) N.O. contact block. E-Stop should have (1) N.C. contact block.
5. Install control system and wire according to diagram included.
6. Set pressure switch. We typically set the pressure switch 150-250psi below relief pressure.
7. Set relief pressure. Most compactors are set at 1800psi or so for timer shifting units. But some are much lower and some higher. If your compactor was limit or pressure shifting the relief is set too high for timer shifting.
8. Set Timers T0 (Forward Time), T1 (Reverse Time), T2 (Multi-Cycle Timer).
9. Enable other features as required.
10. Install data decal and schematic decal.
11. Give us a call if you have any problems.

## Versa-Pak V5 CEX- Getting Started

Versa-Pak V5 is the 5<sup>th</sup> generation of PSI Waste's aftermarket compactor control system designed especially for used stationary, self-contained and apartment style compactors. It provides all of your favorite features including safety and equipment longevity features you won't find in OEM units.

Versa-Pak is a timer shifting unit and has a smart-shift feature that shifts the compactor into reverse if it deadheads for more than a few seconds. There are many settings that can be changed to help you solve problems like poor power.

### A few things to remember

- The controller has a decal on the front to tell you to program version.
- You will use |ESC 0|, |OK 1|, |▼ 2|, |◀ 3|, |▶ 4|, and |▲ 5| buttons to navigate the menu. You can always back up by using the |ESC 0| button.
- All settings are in PARAMETERS. If you are asked for a password, you are in the wrong place. Hit |ESC 0|.
- When changing settings or navigating through PARAMETERS you will use |OK 1| a lot. |OK 1| indicates you want to change the setting or parameter or you are done changing the setting or parameter.
- You change digits not numbers. In other words, if the number is 10 and you are on the zero and press down one time it will be 19 because the 0 will turn into a 9, 1 will stay the same.
- When you use the panel buttons to operate the compactor, you are also navigating the menu. So after each command, press escape (Button 0).
- Since our system is timer shifting- if you install on a pressure shifting, amp shifting, or limit switch shifting unit you will probably need to turn the pressures down. Either way its good practice to check pressures after install.

### Status Screen

The Status Screen lets you know the program version, whether or not you are set to auto start, and error status. To switch to the status screen, press the |ESC 0| button. To change back to the home screen, press |ESC 0| again.

Use the status screen to check for the following.

- Program version will be displayed on line 1
- Auto Count. If unit is set to start automatically using door closes the screen will display "Auto Count" on line 2
- Eye Operation. If unit is set to start automatically using a photo eye, the screen will display "Eye Operate" on line 3. If Eye Operation is displays the Start button will have a 3 second delay.
- Error Status. If unit shut down because of an error, the error will be displayed on line 4.

### Buttons

Buttons on the front of the ZEN perform multiple functions. In addition to setting parameters you can operate the compactor using these buttons. Before attempting this, make sure you know where the power disconnect is. Press the indicated combination of buttons below to perform the listed task. FYI- the buttons still navigate the menu screen so after each command hit the "ESC 0" button to exit the menu so you don't accidentally change a parameter or something.

- Press |ESC 0| and |OK 1| to START compactor.
- Press |ESC 0| and |▼ 2| to STOP compactor.

### Setting Parameters

We have a great youtube video for setting parameters. Please go to [www.versa-pak.net](http://www.versa-pak.net) to watch our 3-1/2min video. If you would rather wing it keep reading. To get to HOME screen turn power off and back on. From HOME screen press |OK 1|▼ 2| ▼ 2|. PARAMETERS should be blinking on and off. Press |OK 1|. Now you will see the 0 of T0 blinking on and off. Press |▼ 2|. You should be on Forward time. Press |OK| to change. Use |▲ 5|▼ 2|▶ 4|◀ 3| to change each digit. You can set Forward and Reverse times down to the 1/10<sup>th</sup> of a second. Once the times are set press |OK| to save. Then navigate up to the parameter T0. To go to a different parameter press |OK| then use |▲ 5| to go to T1. Press |OK|.

To get to a parameter other than "T" then instead of |▲ 5| to go to T1 hit |◀ 3| and then |▼ 2|▼ 2| to go to C0.

### Basic Timer

Parameter Default	Parameter Name	Function	Notes
T0 (S) 19.00	Forward Timer	Ends forward stroke. Set for the time it takes the ram to go from all the way back to all the way forward.	For pressure shifting type cylinders set the time so that the cylinder never bottoms out in either direction. Timers are able to be set down to the 1/100 <sup>th</sup> so no need to bottom out. For bypass type cylinders allow the cylinders to bottom out for a fraction of a second.
T1 (S) 14.00	Reverse Time	Ends reverse stroke. Set for the time it takes the ram to go from all the way forward to all the way back.	
T2 (MM:SS) 01.00	Multi Cycle Timer	Causes compactor to run multiple cycles.	Set T2 for a few seconds shorter than the time it takes to do the number of cycles you want. [T0 + T1] X [Number of cycles] – [5 secs] Compactor will stop at the end of the cycle following T2 timing out.
T3 (MM:SS) Default 10.00	Auto Shut-down	Shuts compactor down if it runs too long.	Reset with E-stop, key switch, or main power.

### Using Fullness Features

Parameter Default/ Suggested	Feature Description	Activate Feature	Notes
#5 (S) 99.99   00.50	Part Full Light Turns on full light (Q3) but compactor continues to operate as usual. Light is reset by E-stop, maintenance door, key switch, or main power. Requires Pressure switch. Set at least 150psi below relief setting.	#5 must be set below Smart Shift timer (Tb) and 100% timer (T4). If you are using pressure shifting cylinders, be sure you are not deadheading forward. Timer is cumulative during multi cycle so you may add time if using pressure shifting cylinders to avoid false alarms.	Timer will ignore first stroke after cycle is interrupted or feed door is opened. So, if using a feed door interlock, the compactor must be set to run two cycles (T2). Only the second cycle will sense for fullness. Not compatible with Motor Off Delay (T6) and Cycle Resume (C1) if using pressure shifting cylinders.
T4 (S) 99.99   02.00	100% Full Turns on full light (Q3). Shuts down compactor immediately. Reset by E-stop, maintenance door, key switch or main power. Requires Pressure switch. Set at least 150psi below relief setting.	T4 must be set below Smart Shift timer (Tb). To use with Part Full feature, it must be set above part full timer (#5). (FYI- V5.4 or above. 80% light will come on as well as 100% light. This gives you the ability to use only one light for both features.)	

### Motor Drives

- Remove jumper from 5A to 4. Not doing so may “FRY” the motor drive (though I’ve never seen it happen)!
- Put the two control wires coming from the motor drive to 5 and 5A.
- Always use a pressure switch or amp switch to limit deadheading of the motor at full pressure.
- Wire up the main power wires using same wire size as a 1 phase motor. For 10HP motor drives you should use 4ga wire on longer runs. Never wire up a 10HP motor drive using less than 6ga wire.
- We also recommend employing recommendations in “Motor Power Issues” section of the manual.

## Errors

Versa-Pak shuts down the compactor if it detects certain errors. In this event the error will be displayed on line 4 of the Status Screen. Check the status screen before clearing the error and correct the issue before continuing to operate compactor. To clear error either press the E-Stop, turn key switch off, or turn power off and back on.

Error	Common Causes	Possible Solution
Motor Overload (Input 5. Kits are not prewired)	This error is caused by the overload relay on the starter tripping Overload setting is wrong	Check Motor issues section of this manual for solutions Set overload setting correctly
Full/ Jam T4 default 99.99 (Full feature OFF)	Either the compactor is full Something blocking the ram in the charge box. Timers are set incorrectly	Empty compactor Clear the hopper and watch the ram cycle. Set timers correctly
Ran Too Long T3 default 10.00 (10min)	T2 (Multi Cycle) is set too high T3 (Auto Shut Down) is set too low Photo eye is dirty or is out of adjustment Start button contacts have moisture  Start wire shorted to power	Correct timer setting Correct timer setting Clean and adjust photo eye, reflector Change out contact, resolve moisture issue. Repair short
PSI Too Long #0 Default 01.00 (1 min)	Pressure switch has been on too long during the run time. This time is cumulative. Parameter #0 is time setting. Compactor was run with hoses disconnected QD's are bad Pressure switch is out of adjustment Pressure switch is bad Oil is too thick or too cold Hoses are too long	Check time setting. Should be 01.00 (1 minute) Connect hoses Replace QD's Adjust pressure switch Replace pressure switch Use thinner oil or let oil warm up Use larger diameter hoses or shorten them in length.

## Motor Power Issues (including 208volt, 10HP/1Ph)

If you are having issues with poor power, you should always make sure to check the following and correct any issues you find.

- Proper wire size for circuit (consider length of run too).
- Good connections (including motor junction box)
- Proper breaker and fuse sizes
- Proper motor wiring
- Disconnect, breaker, starter, etc. are in good working order and properly sized.
- Pressure setting. You should be able to start the power at full pressure unit with hoses not connected to cylinder. (NOT with pressure already on the pump though).
- Size of pump vs motor size. Generally speaking- the GPM of the pump should be no higher than the HP of the motor. So a 10HP/ 1Ph motor should have no more than a 10GPM pump. Smaller is better.
- Check to see if the power unit can be started with the compactor not hooked up. If so, install a "compactor gone" interlock connector to the compactor so when the driver pulls the compactor, he has to disconnect the connector disabling the power unit. Wire up like Maintenance door.

Versa-Pak Features that can help- see appropriate section in manual to use feature

- Smart Shift (Page 5)- Prevents long periods of high pressure. Reduce time setting.
- Forward Delay (Page 5)- Starts motor with valve in center position so that motor never starts under a load.
- Motor Off Delay (Page 5)- allows motor to idle for a period of time so that compactor can be restarted without restarting the motor. This is especially helpful for 10HP/ 1Ph motors.
- For Auto-Count units use Cycle Interrupt Settings (Page 6).

### Smart Shift Adjustments

Parameter Default	Parameter Name	Function	Notes
Tb (S) 02.10	Smart Shift Forward	Shifts compactor from forward to reverse if pressure switch detects pressure for Tb time setting.	Important for pressure shifting compactors. Prevents excessive deadheading.
#4 (S) 04.00	Smart Shift Reverse	Shifts compactor from reverse to forward if pressure switch detects pressure for #4 time setting.	Important for pressure shifting compactors. Prevents excessive deadheading when packing out. This may cause an issue (especially in colder weather) if the back pressure is high in reverse. If so you can shorten and/or oversize hoses.

NOTE 5.1: You can make unit pressure shifting if desired. Set T0 and T1 higher than forward and reverse strokes can take (with Hi Lo pump or Regen set them much higher). Set Tb and #4 to 00.50. Do not set below 00.50 (1/2 Sec) or it may cause a glitch. (Not compatible with fullness features.)

### Time Delay Features

Parameter Default/ Alt	Parameter Name	Function	Notes
T5 (S) 00.01/03.00	Forward Delay	Delays shift of forward solenoid at beginning of cycle.	Requires open or tandem center valve. Allows motor to start under a no-load condition.
Tf (S) 00.01/01.00	Reverse Delay	Delays shift of reverse solenoid when pressing reverse button. Only change if necessary to prevent stalling of motor- mainly in poor power situations.	Requires open or tandem center valve. Allows motor to start under a no-load condition. Note: If running forward and Reverse button is pressed valve will shift to center for Tf time before shifting to Reverse.
T6 (S) 00.01/20.00	Motor off delay	Let's motor idle at end of cycle. Allows repeated starts without re-starting motor.	Requires open or tandem center valve. Great for 1 phase motors or motor drives or very poor power. Works well with auto-count (set C1 for 0001)

## Auto Count Compactors

### Safety Precautions

- Ensure a minimum feet height of 42"
- All access to the charge box must be interlocked.
- With few exceptions that rarely apply- YOU MUST INSTALL A WARNING LIGHT AND HORN and delay start for 20secs according to ANSI standards!
- Install E-Stops at every point of entry.
- Install all safety decals including "This Machine Starts Automatically!"
- If you are not using the warning light and buzzer set T7 to 00.01. This will prevent the time delay start that may fool someone into thinking the compactor is not going to start.

### Using Auto Count

Auto-Count starts the compactor automatically when the feed door (wired to I1) is opened and closed the number of times set on C0 (RES line). Loss of power, E-stop, reverse and start all reset the counts (CNT line of C0) to 0.

### Setting Auto Count

- Install light to Terminals 1 (common) and 14. Install buzzer to terminals 1 and 13.
- Press the |ESC 0| button to go to the Status screen. You should see "V-P V5.X" on line 1.
- Press |ALT 7| and |DEL 6| at the same time. This will enable Auto Count. You should see "Auto Count" on line 2.
- Make sure your feed doors are wired as "Feed Door". DO NOT wire them parallel to the E-stop. See drawing.
- Check T7 to ensure proper setting.
- Set C0. See "Setting Parameters" section of this manual.
- Set additional options as desired.

Parameter Default/ Suggested Setting	Parameter Name	Function	Notes
C0 9999/0003	Auto Count Setting	Sets number of door closes (C0) to initiate auto-count feature.	Requires warning light and buzzer. See other
C1 9999/0001	Cycle interrupted Setting	Will restart cycle after door is opened and closed.	Requires T6 to be active along with an open or tandem center valve.
T7 (S) 20.00	ANSI Delay	Delays start for ANSI required 20 secs.	Warning light and buzzer will start to warn anyone in area of danger.
T6 (S) 00.01/ 20.01	Motor Off Delay	Stops movement of ram if door is opened but motor continues to run.	Requires tandem or open center valve. Works with C1.

Note 6.1: If compactor has no power for more than 2 days, you may have to re-initiate count using |ALT 7| and |DEL 6|. Confirm Auto Count status on Status Screen. This may apply to Second part of Note: 6.2 as well.

Note 6.2: If you choose not to use the warning light and buzzer you should set Timer T7 to 00.01.

Note 6.3: If you need a flashing output for Horn you can change T9 from "O" to "F" type and set to 06.00. Call PSI Tech support to figure out how.

### Cancel Auto Count

- To cancel Auto Count Push |ALT 7| and |DEL 6| at the same time again. Line 2 of status screen should be blank now.
- After canceling Auto Count Set C0 to 9999 also as an additional precaution.

## Eye Operated Compactors

### Safety Precautions

- Ensure a minimum feet height of 42"
- All access to the charge box must be interlocked.
- With few exceptions that rarely apply- YOU MUST INSTALL A WARNING LIGHT AND HORN and delay start for 20secs according to ANSI standards!
- Use only Maintained (Push/Pull) Emergency Stop buttons. Install E-Stops at every point of entry.
- Install all safety decals including "This Machine Starts Automatically!"

NOTE: If you are not using the warning light and buzzer set T7 to 00.01. This will prevent the time delay start that may fool someone into thinking the compactor is not going to start.

### Photo Eye Installation

Note: Photo eyes are not desirable in most situations. They are best used in applications where access to the charge chamber is limited (like in an apt style unit with limited access and a small door).

### Installing Eye

NOTE: We suggest buying an electric eye from us so that we can support you better. If you buy one on your own, we will not be able to fully support the install. We'll help you if we can though.

- Install light to Terminals 1 (common) and 14. Install buzzer to terminals 1 and 13.
- Press the |ESC 0| button to go to the Status screen. You should see "V-P V5.X" on line 1.
- Push |ALT 7| and |◀ 3| at the same time. This will enable Eye Operate. You should see "Eye Operate" on line 3.
- Make sure T7 is set at 20.00 (Factory setting, ANSI delay start)
- Wire the N.O. contact parallel to the start button (#4 and #8)
- Wire the eye power to terminal blocks #4 (hot) and #1 (common)
- Install light to Terminals 1 (common) and 14. Install buzzer to terminals 1 and 13.

Parameter Default	Parameter Name	Function	Notes
T7 (S) 20.00	ANSI Delay	Delays start for ANSI required 20 secs.	Warning light and buzzer will start to warn anyone in area of danger.
#2 (S) 03.00	Time Delay Eye	Delays compactor start when eye is blocked. Prevents compactor from starting every time trash passes eye.	Also delays start button. So you'll have to hold start button down for same time (#2)
T3 (MM:SS) 10.00	Auto Shut-down	Shuts compactor down if it runs too long.	Set higher than eye is likely to be blocked. Reset with E-stop, key switch, or main power.

Note 7.1: If compactor has no power for more than 2 days, you may have to re-initiate count using B7 and B3. Confirm Auto Count status on Status Screen. Also this may apply to Note: 7.3 as well.

Note 7.2: If you choose not to use the warning light and buzzer you should set this timer to 00.01. Full Feature lights with still not work properly. If you have V5.2 or higher, also see Note 7.3 to make compatible with Full Features.

Note 7.3: If you need a flashing output for Horn you can change T9 from "O" to "F" type and set to 06.00. Call PSI Tech support to figure out how.

### Cancel Eye Operate

- To cancel Auto Count Push |ALT 7| and |◀ 3| at the same time again. Line 3 of status screen should be blank now.

# INSTALL DIAGRAM

When removing the wires from the transformer and starter, cut the wires leaving them attached to the terminals. This will make it easy to identify where the new wires go during the install. Connect new wires from Versa-Pak to each component as previously connected. Versa-Pak does not use auxiliary contacts on the starter. These wires can be removed.

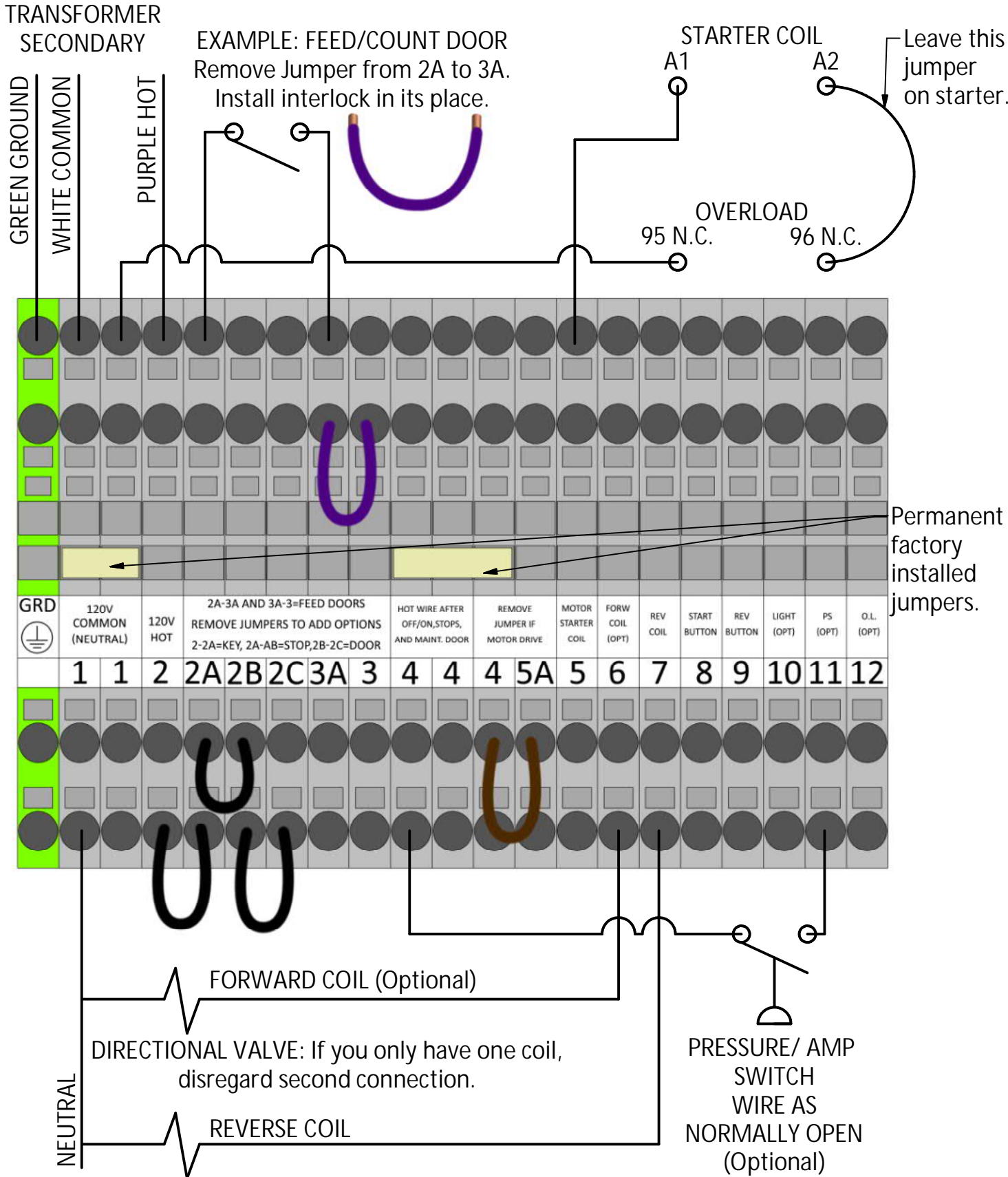



## EXPLANATION OF JUMPERS

Jumpers are used to complete the control circuit when options are not needed. They can be removed only when replacing with the appropriate component.

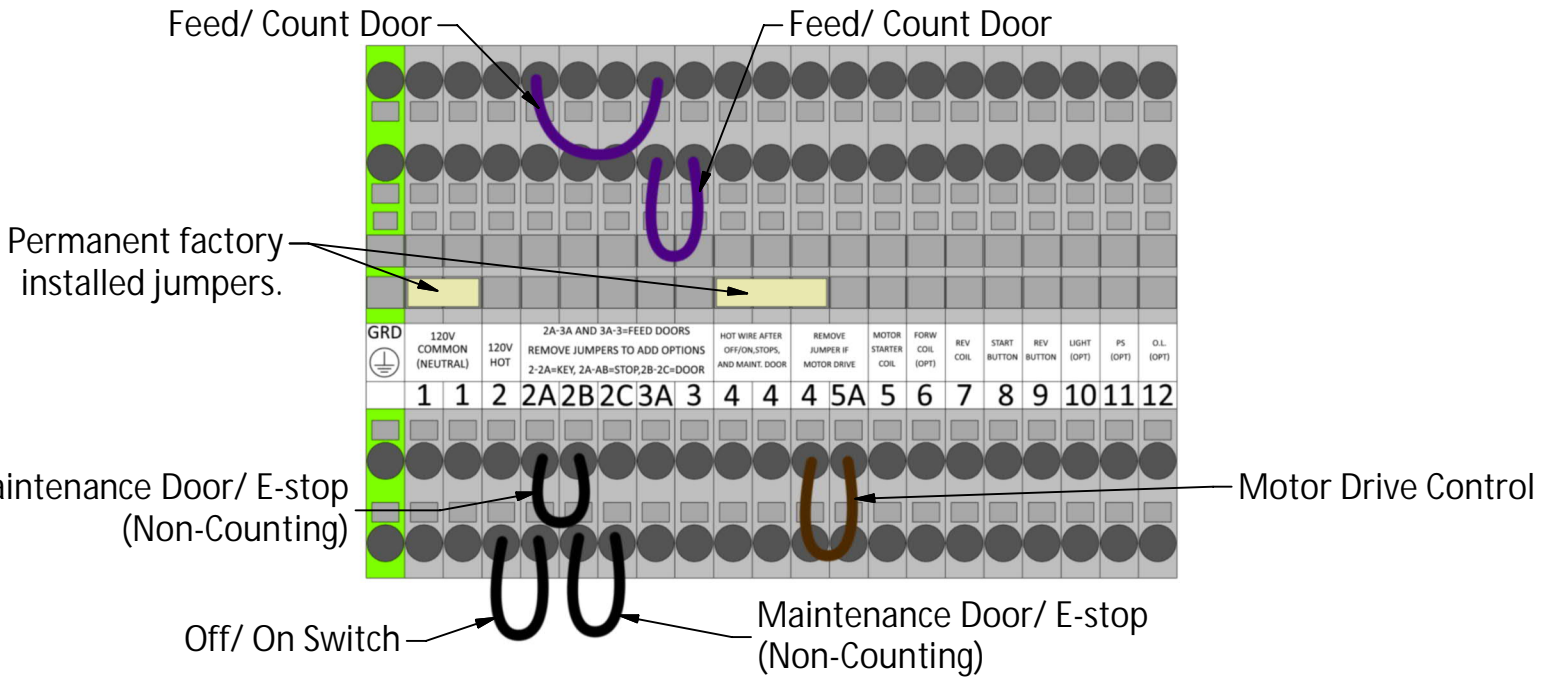
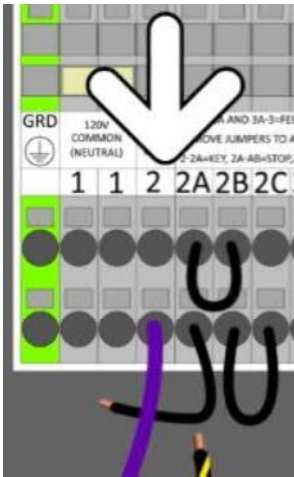

Fig. A



### EXAMPLE

#### INSTALLING OFF/ ON SWITCH

For instance, if you were wiring in an Off/ On switch, you would remove the jumper from 2 and 2A and replace it with the wires coming from the normally opened contact of the switch. See Fig. A. and Fig. B. Other black or purple jumpers work the same.

Fig. B

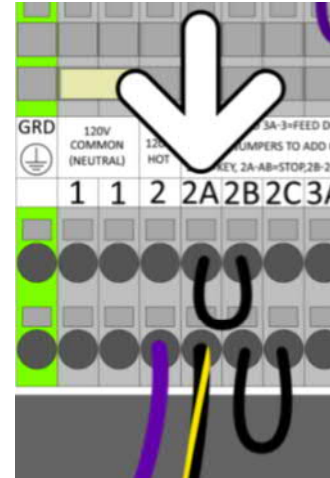
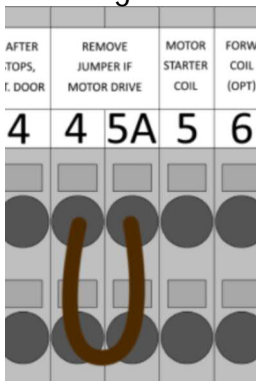

Fig. C



### EXAMPLE

#### IF INSTALLING VERSA-PAK WITH A MOTOR (VECTOR) DRIVE

Jumper 4 to 5A (Fig. C). This jumper is removed ONLY when wiring in a Motor Drive. In this instance, the jumper will be removed, BUT the Motor Drive Control Wires will wire into 5A and 5 (Fig. D).

**\*DO NOT REMOVE 4 TO 5A JUMPER UNLESS YOU ARE USING A MOTOR DRIVE\***

Fig. D

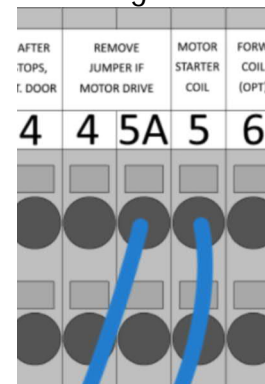

# Typical Controls Wiring

Check schematic for more options.

## Off/On, Start, Reverse, Stop

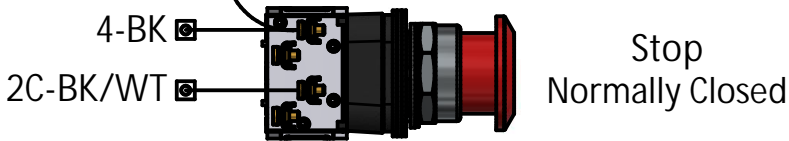
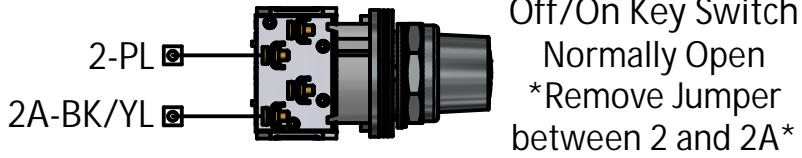

## Start, Reverse, Stop

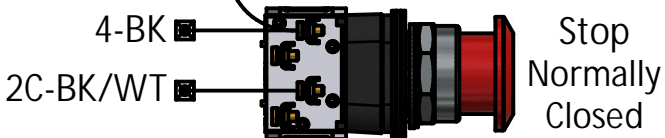
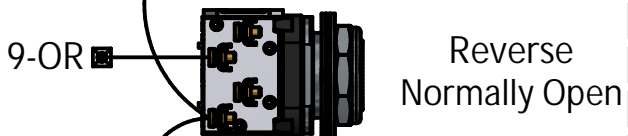
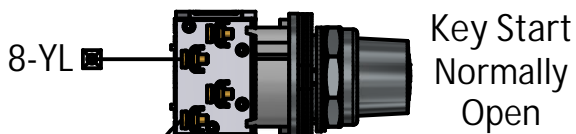

## Stop w/ Feed Door

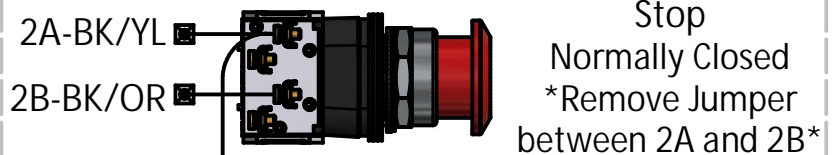

Normal / Off / Manual, Manual Forward/ Reverse  
 When switch is in Driver, all E-Stops/ Interlocks will be bypassed.  
 Forward and Reverse switch will Start motor and Jog ram.

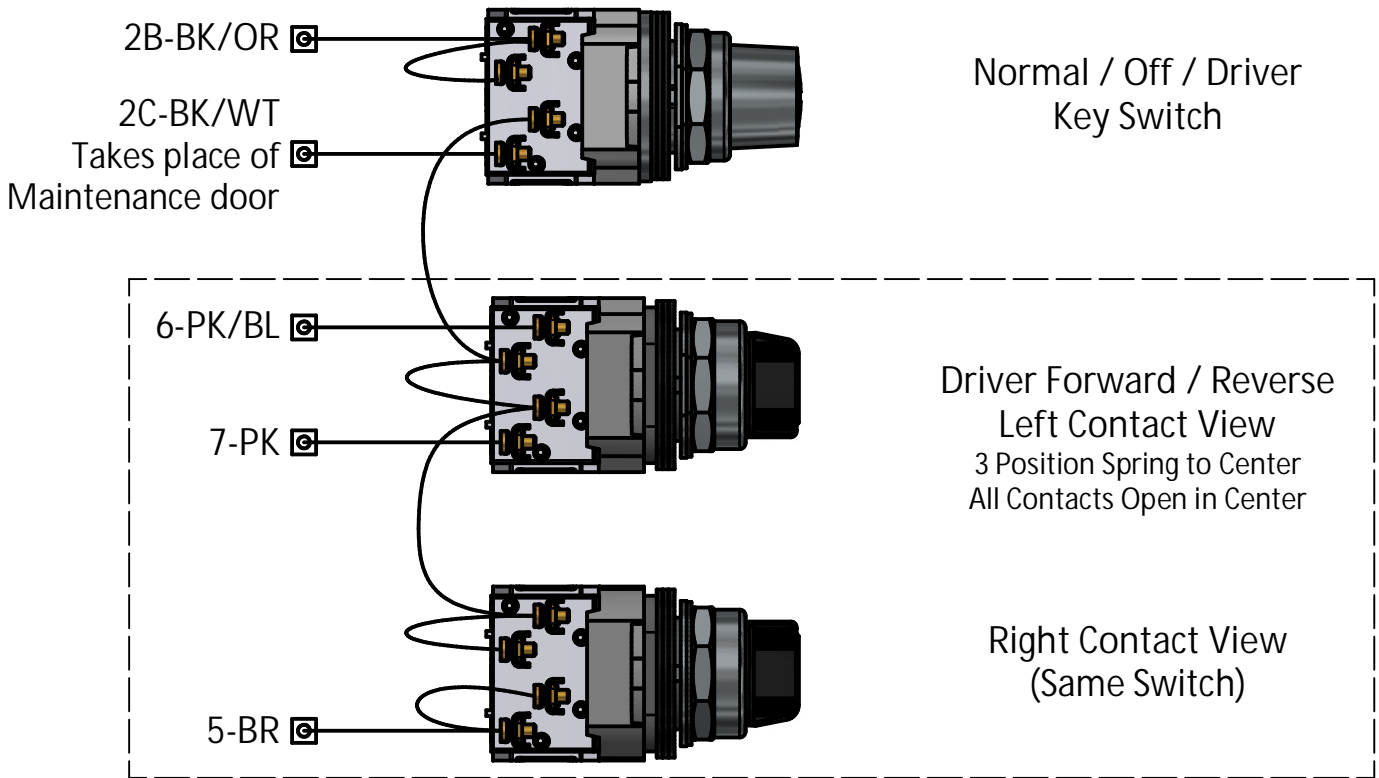

### LOW VOLTAGE FEED DOOR INTERLOCK

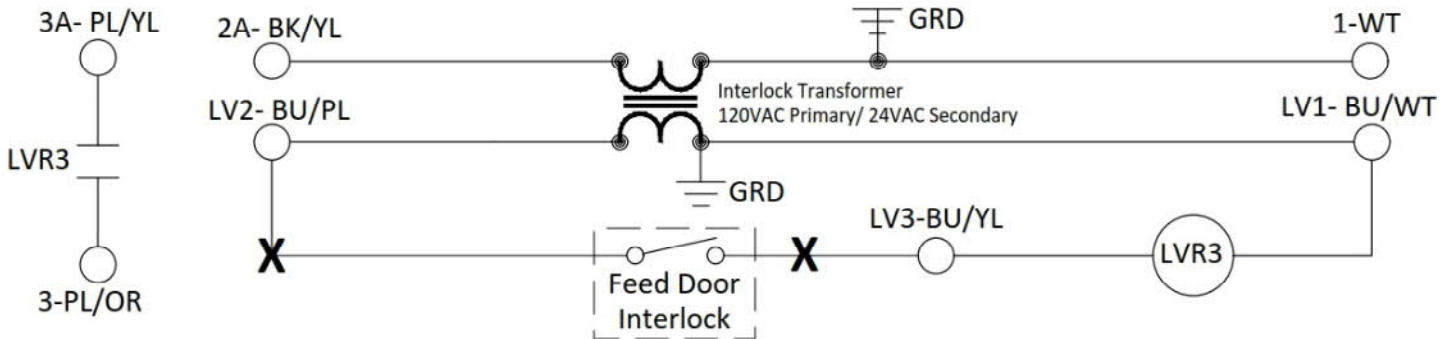

### LOW VOLTAGE E-STOP OR MAINTENANCE DOOR

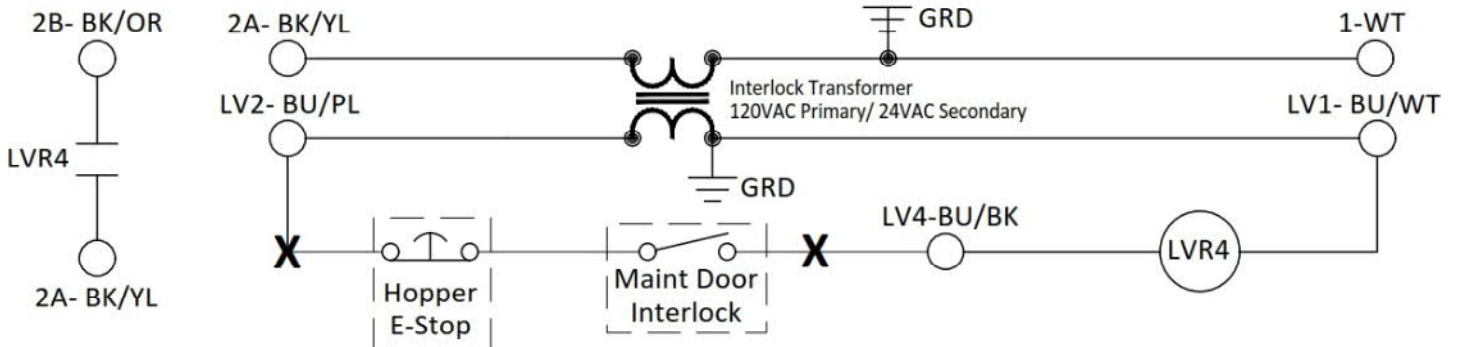

"X" indicates interlock plug. "LV\_" are additional low voltage terminal blocks.  
 Call PSI Waste if you need LV terminal blocks at no charge.  
 "LVR3" and "LVR4" are 24VAC relays(not provided).

Notes:  
 Both E-stops act the same.  
 Both feed doors act the same.  
 Maint door acts like E-stop. It does NOT count.  
 Wire Start and Reverse parallel for additional stations.  
 \* Optional Components- Remove jumper if used.  
 \*\* Omit connection if not used.

Main disconnect/ branch circuit protection must be supplied by customer. Refer to fuse and breaker chart and local codes.

\*\*\*For single phase jump T2 to L3 on starter, connect motor to T1 and T3.

Note for Auto-Start users:  
 If compactor is down for more than two days, feature may need to be reset. Check Status of Auto-Start features by pressing [ESC 0] until you see status screen.  
 Status screen:  
 Line 1- Program Version  
 Line 2- Auto-Count  
 Line 3- Eye Operate  
 If required feature is not listed, reset by pressing:  
 Auto-Count- [ALT 7] and [DEL 6] at the same time.  
 Eye Operate- [ALT 7] and [< 3] at the same time.

Basic Timers:  
 T0-Forward  
 T1-Reverse  
 T2-Multi Cycle Timer  
 T3-Auto Shut Down  
 C0-Counter

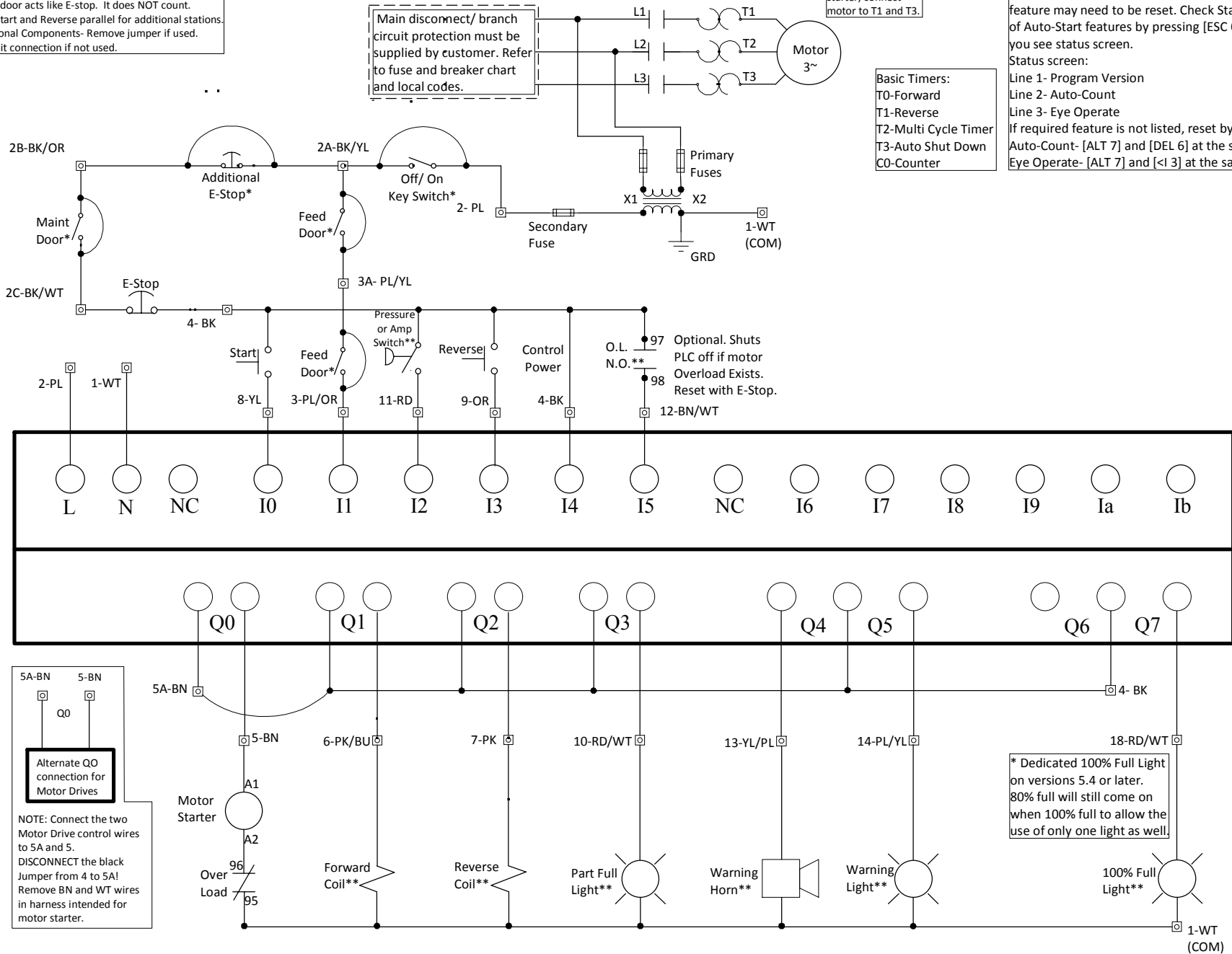

5A-BN 5-BN  
 Q0

Alternate Q0 connection for Motor Drives

NOTE: Connect the two Motor Drive control wires to 5A and 5.  
 DISCONNECT the black Jumper from 4 to 5A!  
 Remove BN and WT wires in harness intended for motor starter.

\* Dedicated 100% Full Light on versions 5.4 or later. 80% full will still come on when 100% full to allow the use of only one light as well.

Description: Versa-Pak V5 CEX Wiring. For support go to [www.versa-pak.net](http://www.versa-pak.net) or call 352-742-4774.